

# Non-linear finite element analysis of reinforced concrete: at the crossroads?

F. J. Vecchio University of Toronto, Canada

**This article takes a critical look at the relevance and value of non-linear finite element procedures for analysis and design of reinforced concrete structures. Their potential usefulness as a practical design office tool is illustrated through a sample application. Then, in examining the results of recent prediction competitions, the accuracy of such analysis procedures is examined. Reasons for caution when applying non-linear analysis methods are identified and discussed. Finally, the results of a test programme involving shear critical beams are presented in support of the contention that the behaviour of reinforced concrete is still not always well understood; the test results provide a challenge for validating current procedures.**

## Notation

$A_{gm}$	maximum aggregate size
$A_s$	cross section area of rebar
$D$	rebar diameter
$f'_c$	compressive strength of concrete cylinder at 28 days
$f'_t$	tensile strength of concrete
$f_y$	yield strength of reinforcement
$M_u$	section moment capacity of beam (hand calculated)
$P_u$	ultimate load capacity of beam (finite element analysis)
$V_{u1}$	sectional shear capacity of beam (Simple Method of CSA A23.3)
$V_{u2}$	sectional shear capacity of beam (General Method of CSA A23.3)
$\delta_u$	midspan deflection at ultimate load (finite element analysis)
$\epsilon_o$	concrete strain at peak compressive stress
$\gamma$	shear strain
$\rho$	reinforcement ratio
$\tau$	shear stress

## Introduction

Non-linear finite element analysis (NLFEA) of reinforced concrete has taken tremendous strides forward since initial applications about 40 years ago. Much research activity has occurred in the realm of constitutive modelling of reinforced concrete behaviour and in the development of sophisticated analysis algorithms. These advancements are well documented in various state-of-

the-art reports, and still remain the subject of many specialty symposia and workshops.

Occurring at the same time, and no less significant, has been the prodigious advancement in computing technology and hardware. Data compiled by Bentz, shown in Figure 1, provide a clear measure of the exponential growth in computing power in recent years.<sup>1</sup> Shown is the time required to conduct a non-linear shear analysis of a prestressed T-beam using a layered beam element algorithm. It is seen from the graph that, in 25 years, computing speed has increased by five orders of magnitude. Analyses that required several days of CPU time on supercomputers two decades ago run in minutes on personal desktop computers today. The advent of powerful and relatively inexpensive computers has greatly expanded the size and complexity of problems that can be analysed, and has greatly reduced the computer time required for their solution.

The state-of-the-art in NLFEA has thus progressed to the point where such procedures are close to being practical, every-day tools for design office engineers. No longer solely within the purview of researchers, they are finding use in various applications; many relating to our aging infrastructure. NLFEA procedures can be used to provide reliable assessments of the strength and integrity of damaged or deteriorated structures, or of structures built to superseded codes, standards or practices deemed to be deficient today. They can serve as valuable tools in assessing the expected behaviour from retrofitted structures, or in investigating and rationally selecting amongst various repair alternatives. In situations that have not turned out well, NLFEA procedures are

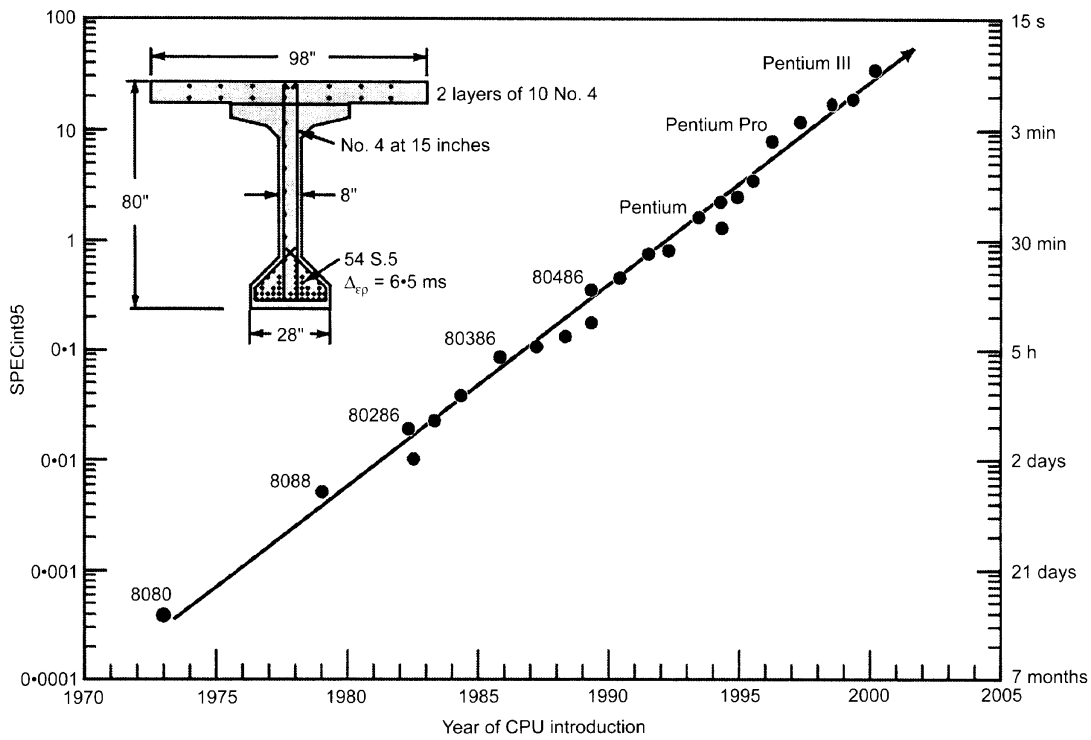

Fig. 1 Increase in computing power in recent years<sup>1</sup>

finding applications to forensic analyses and litigations that follow. In the near future, they will likely form the main engine in computer-based automated design software, although in a form likely invisible to the user.

### A sample application

As an example of the usefulness of NLFEA methods, the studies undertaken subsequent to the collapse of the Sleipner A offshore platform will be briefly reviewed. The gravity base structure of the platform consisted of a cluster of 24 cells, four of which extended upwards to form shafts (see Figure 2). While the exterior of the walls of the cells were circular, the interior walls separating the cells were straight. At the intersection of these interior walls, a small triangular void called a tricell was formed (32 in total). These tricells had openings at the top, and hence had to resist substantial hydrostatic pressure when submerged.

On 23 August 1991, the gravity base structure was slowly being submerged as part of the deck-mating operation. The intent was to lower the structure until its base was 104 m below the ocean surface. However, when a depth of 99 m was reached, a loud rumbling noise emanated from one of the drill shafts and water could be heard pouring in. Within minutes, the structure began to sink in an uncontrolled manner. Moments after disappearing below the surface, a series of implosions were felt as the buoyancy cells collapsed. Evidence showed that the loss of the structure was attributable to the shear failure of one of the tricell walls.

To develop a better understanding of the factors influencing the failure of the tricell wall, a series of non-linear finite element analyses were undertaken. The finite element model used, represented in Figure 3(a), is fully described by Collins *et al.*<sup>2</sup> Initial analyses indicated that the as-built structure would fail in shear when the applied water pressure on the inner faces of the tricells

reached 625 kN/m<sup>2</sup>. This corresponded to a head of seawater of 62 m, a value that agreed well with the estimated 65 m head active at the cell wall location where collapse occurred.

The designers of the structure were interested in learning how the strength of the tricell would have changed if the stirrups, which were terminated just below the failure location, had been continued further up the wall. They also wanted to know how the length of the T-headed bars used in the throat of the tricell walls influenced the behaviour. Additional finite element analyses were conducted, and the results are summarised in Figure 3(b). The results of these studies indicated that the tricells could have resisted an additional 20 m of water head if either the stirrups had been continued up the wall or if the T-headed bars had been about 500 mm longer.<sup>3</sup> Changes were made to the design of replacement structure accordingly.

### The question of accuracy

Despite the increasing sophistication of NLFEA tools, users must be ever mindful of the question of how accurately and reliably they represent the behaviour of reinforced concrete structures. In this regard, it is useful to examine the results of three 'prediction competitions'.

At the 1981 IABSE Symposium in Delft, a 'blind' competition was organised involving four panels tested in a comprehensive research programme then underway at the University of Toronto. The test panels were orthogonally reinforced, and subjected to uniform, proportional and monotonically increasing stress conditions; seemingly a very simple problem to model and analyse. The results of these panel tests were not disclosed prior to analysts submitting their predictions of strength and load-deformation response. Approximately 30 entries were received, many from the leading researchers in the field at the time. Shown in Figure 4 is the range of responses for Panel C, one of the better pre-

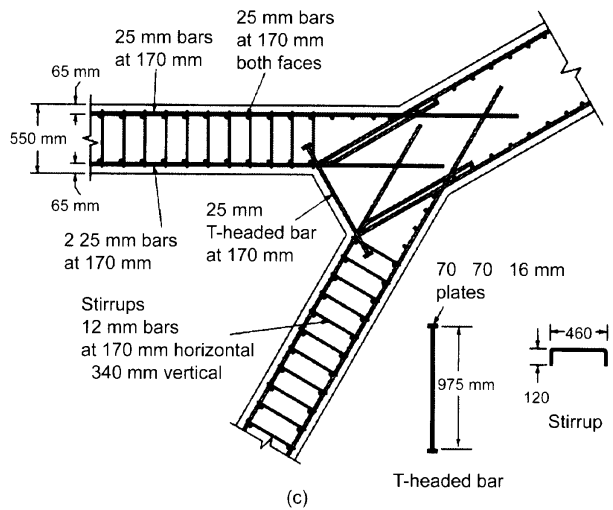
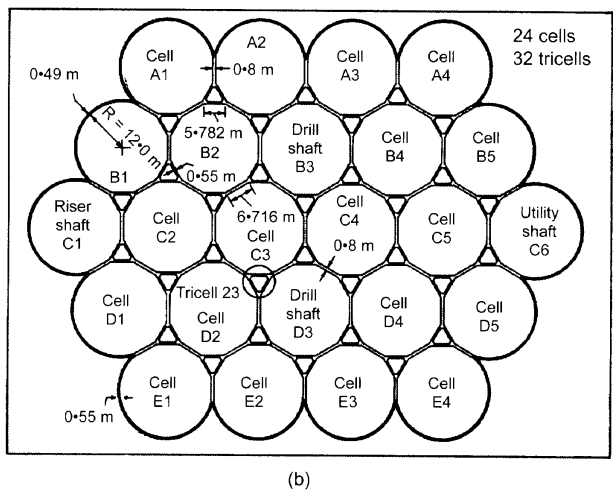
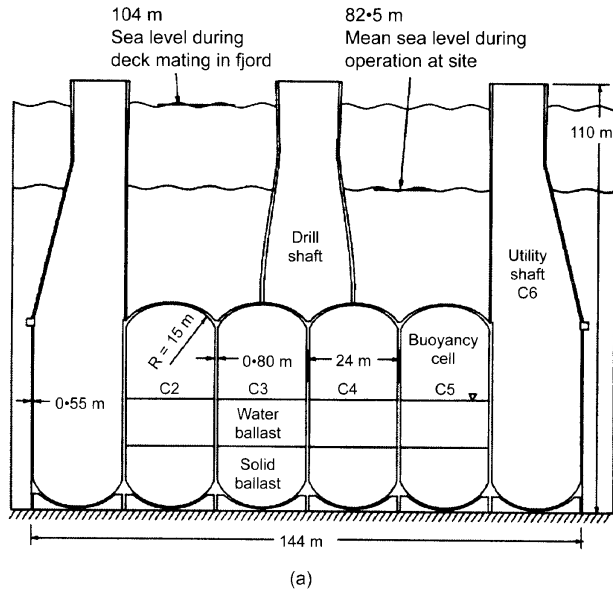

Fig. 2 Details of the Sleipner A concrete base structure

dicted of the four panels. The analysis results submitted showed a wide variation in predictions of the panel's shear strength, and an even wider divergence in computed load–deformation responses.<sup>3</sup> Clearly the collective ability to model non-linear behaviour of reinforced concrete, particularly in shear-critical conditions, was not well advanced.

More recently, in 1995, the Nuclear Power Engineering Corporation of Japan (NUPEC) staged a prediction competition involving a large-scale 3-D shear wall subjected to dynamic cyclic loading.<sup>4</sup> The flanged shear wall exhibited highly non-linear behaviour before sustaining a sliding shear failure along the base of the web. One facet of the competition called for estimates of the ultimate strength, and corresponding displacement, of the wall as determined from static push-over analyses. Again, over 30 sets of predictions were received; the results are summarised in Figure 5. The predictions of strength, as a group, showed better correlation than was seen with the Toronto panels; however, the deformation estimates still showed large scatter. Nevertheless, it could be concluded that the ability of NLFEA to accurately capture the behaviour of reinforced concrete had measurably advanced. It should be noted, however, that this was not a completely blind competition since some of the test results had been disclosed to analysts prior to competition.

More recently, ASCE-ACI Committee 447 organised an informal competition centred on results from a series of large-scale columns tested at the University of California at San Diego. Many of the analyses undertaken are documented in papers contained within an ACI Special Publication.<sup>5</sup> From these, it can be noted that: (i) a number of quite different analysis approaches were taken; (ii) predictions of strength and pre-peak response generally correlated well with the experimental results; and (iii) predictions of post-peak response were generally not as accurate and still require further attention. (Bear in mind, once again, that this was not a blind competition. Analysts had the opportunity to calibrate parameters, optimise material models, and refine analyses. One should also bear in mind that experimental results themselves are subject to scatter and error. Repeating a test, particularly if conducted at different laboratories, may yield differing results.)

Nevertheless, it is an inevitable conclusion that our ability to accurately model the behaviour of reinforced concrete structures has seen significant improvement over the past 20 years. It has approached a stage of development where we may be inclined to proceed with a certain degree of confidence.

### Reasons for caution

Despite these significant advancements in our ability to accurately model the response of reinforced concrete, the users of NLFEA procedures need to be mindful of several issues and potential dangers:

#### Diversity of theoretical approaches

A number of rather diverse approaches exist for NLFEA modelling of reinforced concrete structures. Among those available are models built on non-linear elasticity, plasticity, fracture mechanics, damage continuum mechanics, endochronic theory, or other hybrid formulations. Cracking can be modelled discretely, or using smeared crack approaches; the latter can range from fully rotating crack models, to fixed crack models, to multiple non-orthogonal crack models, to hybrid crack models. Some approaches place heavy emphasis on classical mechanics formulations, others draw more heavily on empirical data and phenomenological models. It can generally be said of any approach that it will be more suited to certain structure/loading situations and less so to others. No one approach performs well over the entire

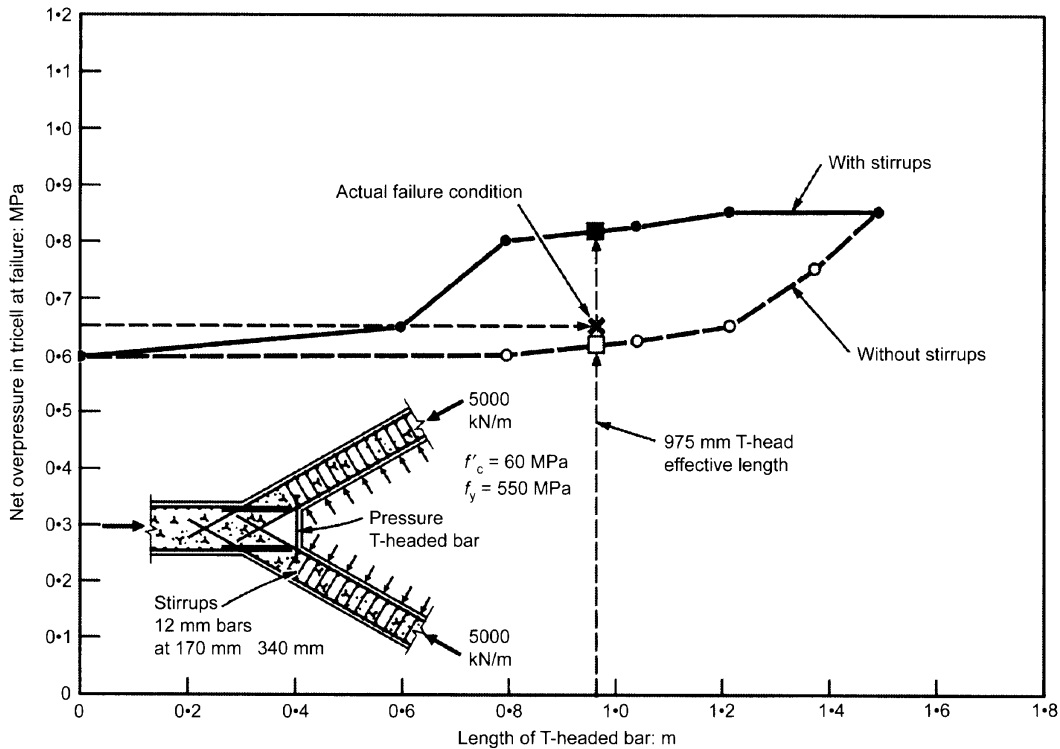
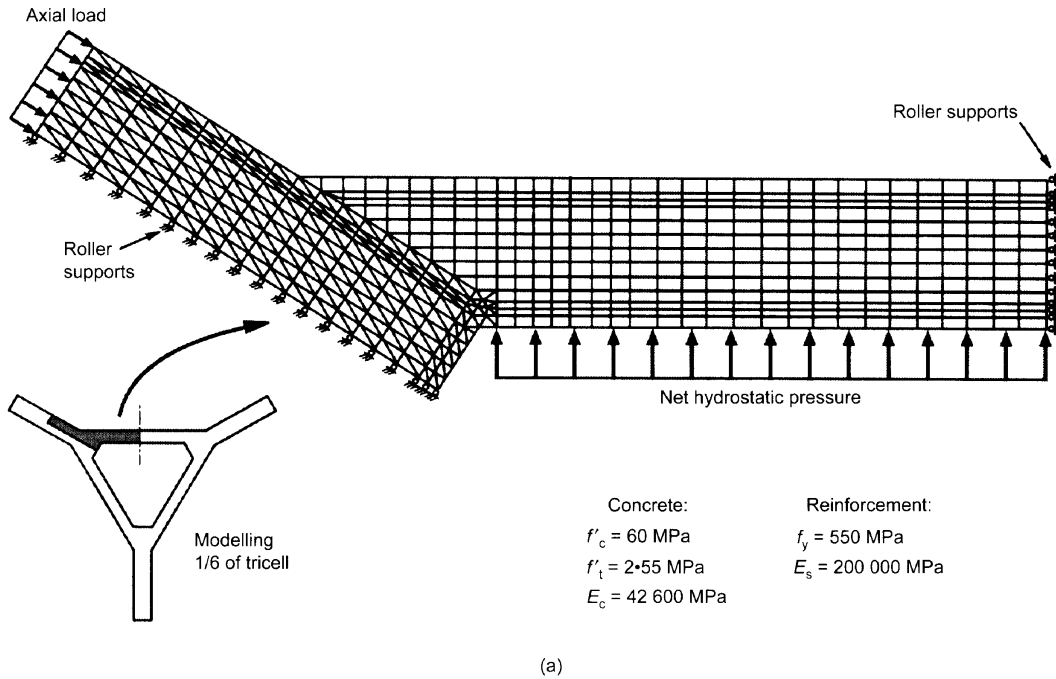

Fig. 3 (a) Finite element model of the tricell; (b) Computed influence of stirrups and T-headed bar on failure pressure

range of structural details and loading conditions encountered in practice.

*Diversity of behaviour models*

Reinforced concrete structures, particularly in their cracked states, are dominated in their behaviour by a number of second-order mechanisms and influencing factors. Depending on the particular details and conditions prevailing, a structure's strength, deflection, ductility and failure mode may be signifi-

cantly affected by mechanisms such as: compression softening due to transverse cracking, tension stiffening, tension softening, aggregate interlock and crack shear slip, rebar bond slip, rebar dowel action, rebar compression buckling, scale effects, and creep and shrinkage, to name a few. For each of these, a number of diverse formulations can exist. In the case of tension stiffening, for example, the stiffening effect can be ascribed to a post-cracking average tensile stress in the concrete or, quite differently, to the load–deformation response of the reinforcement. The user of a NLFEA software must be aware of what

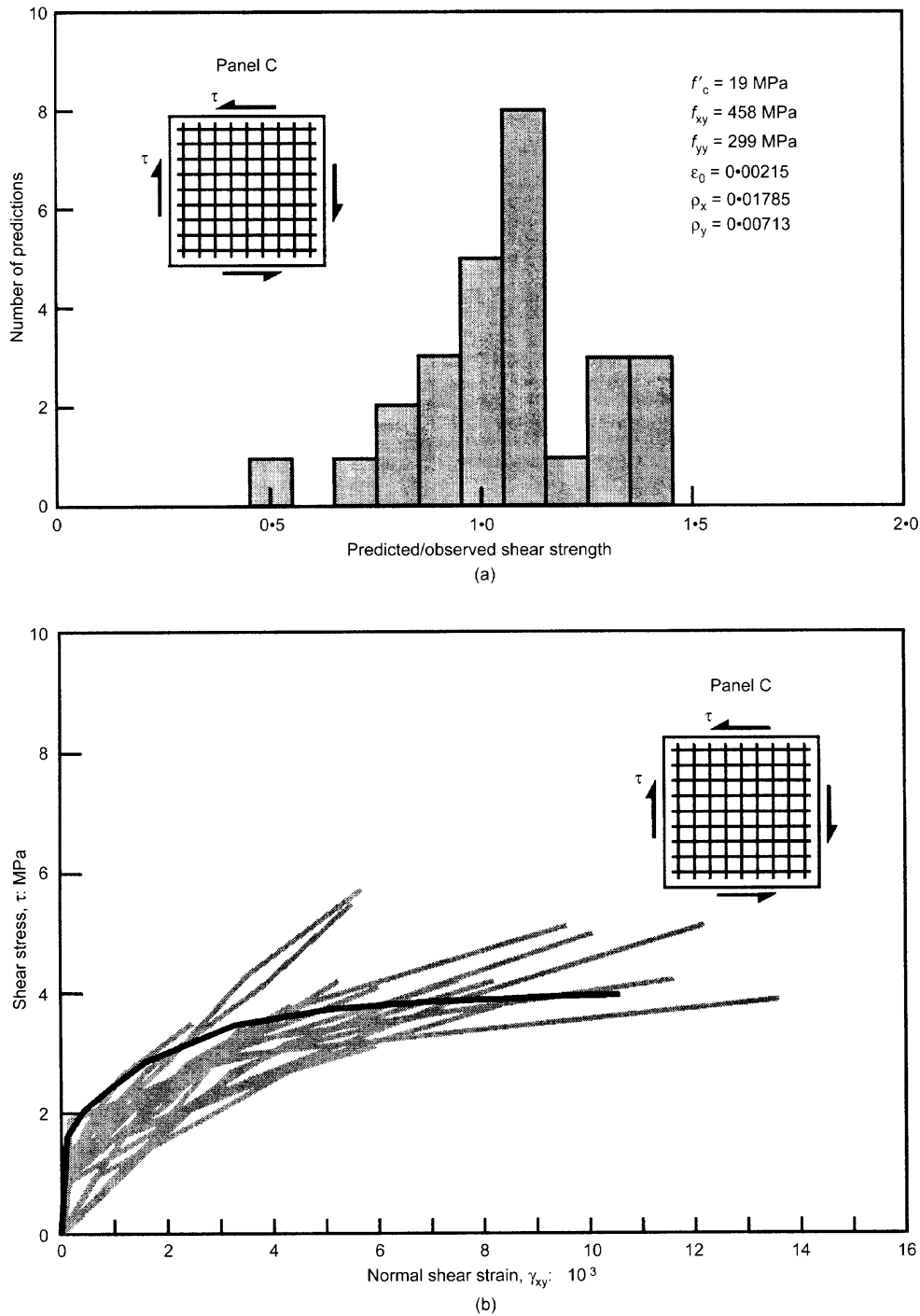

Fig. 4 Delft Panel competition results (Panel C): (a) Variations in predicted shear strength; (b) Variations in predicted load–deformation response

mechanisms are likely to be significant in the problem at hand, be certain that they are included in the analysis model, and have some confidence that the model being used is reasonably accurate.

*Incompatibility of models and approaches*

The formulation and calibration of a concrete behaviour model, as it is being developed, is often dependent on the particular analysis methodology being used. As a consequence, some models cannot be randomly transplanted from one analysis approach to another, or freely combined with other models.

Often, they are developed in combination with other complementary material models, or analysis approaches, and should not be separated. As a case in point, consider the observed and predicted behaviour of Panel PV19;<sup>6</sup> this was, in fact, Panel C from the 1981 Delft Competition, represented in Figure 4. An important mechanism influencing the shear strength and deformation response of this element was the softening of the concrete in compression due to transverse cracking, with the panel eventually sustaining a concrete shear failure. Shown in Figure 6 are the predicted responses obtained using the compression softening model of Vecchio and Collins<sup>6</sup> implemented in a rotating crack formulation, and that of Maekawa<sup>7</sup> implemented in a

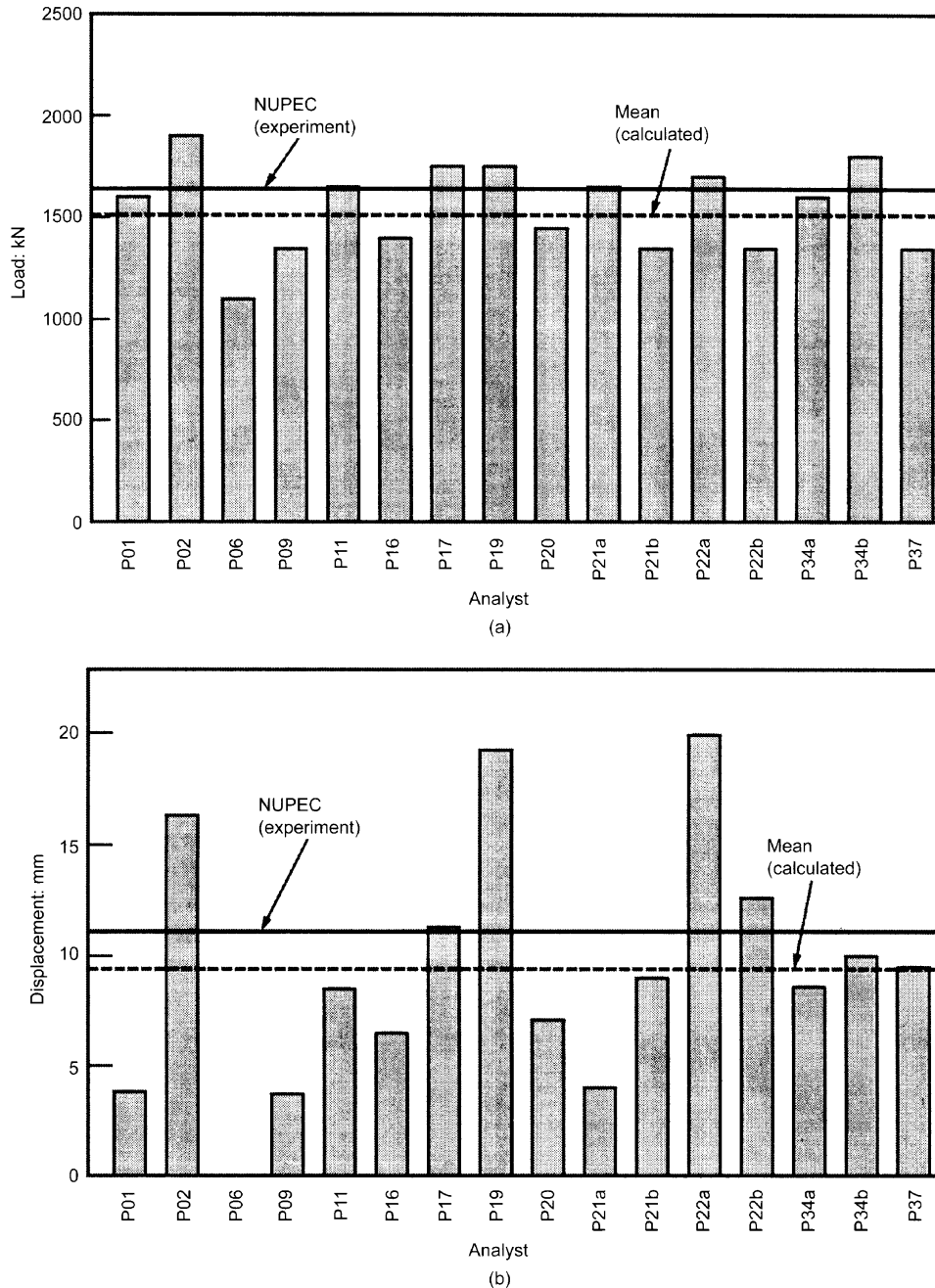
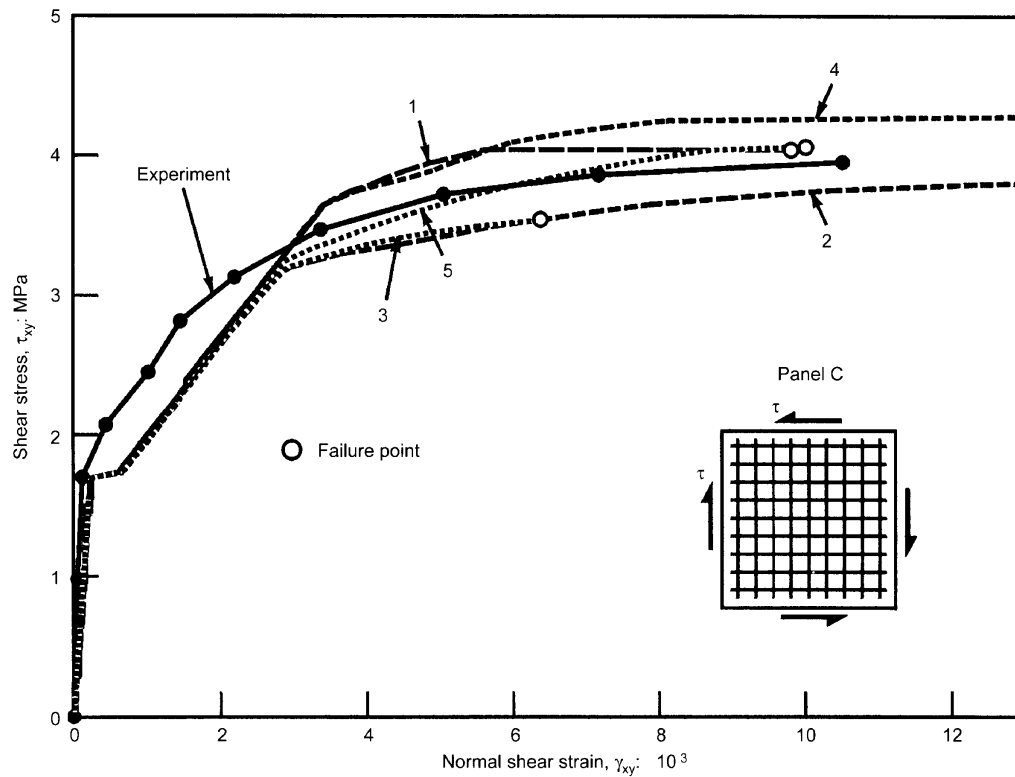

**Fig. 5** NUPEC Wall prediction results: (a) Variations in predicted lateral load capacity; (b) Variations in predicted lateral displacement at ultimate load

fixed crack formulation (i.e. each correctly matched with the crack model for which it was first developed). Both provide equally good simulations of response. The Vecchio–Collins formulation slightly over-estimates strength and slightly under-estimates ductility. Conversely, the Maekawa formulation slightly under-estimates strength and slightly over-estimates ductility. Either one, however, is certainly well within the margins of accuracy we can hope to achieve with NLFEA. But consider the consequences if one implements the Vecchio–Collins model into a fixed crack formulation, or if one uses the Maekawa model in a rotating crack formulation. In both cases, the results are much less satisfactory; strength, ductility and failure mode are subject to significant miscalculation. As it turns out, a hybrid formulation between fixed and rotating crack models<sup>8</sup> provides the most accurate simulation in this case.

#### *Experience required*

Use of NLFEA for modelling and analysis of reinforced concrete structures requires a certain amount of experience and expertise. Unlike, say, the use of plane section analysis techniques to calculate the flexural strength of a beam cross section, the application is rarely straight-forward. Decisions made with respect to modelling of the structure and selection of material behaviour models will have significant impact on the results obtained. Again, unlike sectional analysis techniques, two analysts may well get widely diverging results when modelling the same structure using the same analytical model and the same software. Decisions made regarding mesh layout, type of element used, representation of reinforcement details, support conditions, method of loading, convergence criteria, and selection of material



Analysis series	Constitutive model	Crack model	$\tau_u$ : MPa	$\gamma_u$ : $10^3$	Failure mode
1	Vecchio-Collins	Rotating	4.05	9.80	Conc. shear
2	Maekawa	Fixed	3.85	16.51	Conc. shear
3	Vecchio-Collins	Fixed	3.55	6.42	Conc. shear
4	Maekawa	Rotating	4.45	73.79	Rebar yield
5	DSFM	Hybrid	4.07	10.02	Conc. shear
Experiment			3.96	10.51	Conc. shear

Fig. 6 Influence of compression softening model on computed load–deformation response of Panel PV19

behaviour model, will produce a divergence of results. (Here lies the explanation for the significant difference in accuracy of results obtained in 'blind' competitions as opposed to those obtained when the desired results are known in advance.) Add to this the increased likelihood of errors in input due to the relative complexity of NLFEA.

As an illustration, consider the two simply-supported beams shown in Figure 7, tested by Podgorniak–Stanik;<sup>9</sup> one with shear reinforcement and one without. Ten analysts, all using the same software program (VecTor2) and all previously experienced in its use, were asked to independently provide predictions of the expected load capacity ( $P_u$ ) and corresponding midspan deflection ( $\delta_u$ ) for these shear-critical beams. Also requested were: the theoretical section moment capacity ( $M_u$ ) determined using hand calculations based on the common rectangular stress block approach; the sectional shear capacity ( $V_{u1}$ ) determined using the simple method of the Canadian code specifications, which is essentially the standard 45-degree truss model; and the sectional shear capacity ( $V_{u2}$ ) determined using the general method of the Canadian code specifications, ostensibly a more accurate calculation involving the consideration of compatibility conditions, inclination of the stress field, and reduction in concrete

strength due to transverse cracking. The results are summarised in Table 1.

The calculations of moment capacity, using simple hand methods, were consistent amongst analysts for both beams, showing a coefficient of variation (COV) of less than 3.5%. Calculations of the shear capacity using code specifications produced larger variations. It is interesting to note that the calculation of  $V_{u1}$  (simple method) was not any less scattered than that of  $V_{u2}$  (general method), due to some ambiguity present in the current code formulations making interpretations of the code provisions subjective in certain situations. Also note that the results are significantly more scattered for the beam without shear reinforcement (Beam No. 2), as one might expect. Finally, examine the results obtained from the finite element analyses. The estimates of load capacity ( $P_u$ ) are relatively close to the code-calculated shear capacities, but show significantly more scatter with COVs of about 17% for the beam containing shear reinforcement, and 28% for the beam containing no web steel. The estimates of deflection at ultimate load ( $\delta_u$ ) were widely divergent, in part because some analysts were predicting a brittle shear failure and others a ductile flexural failure. It is worth repeating that the same finite element programme was used by the analysts, all

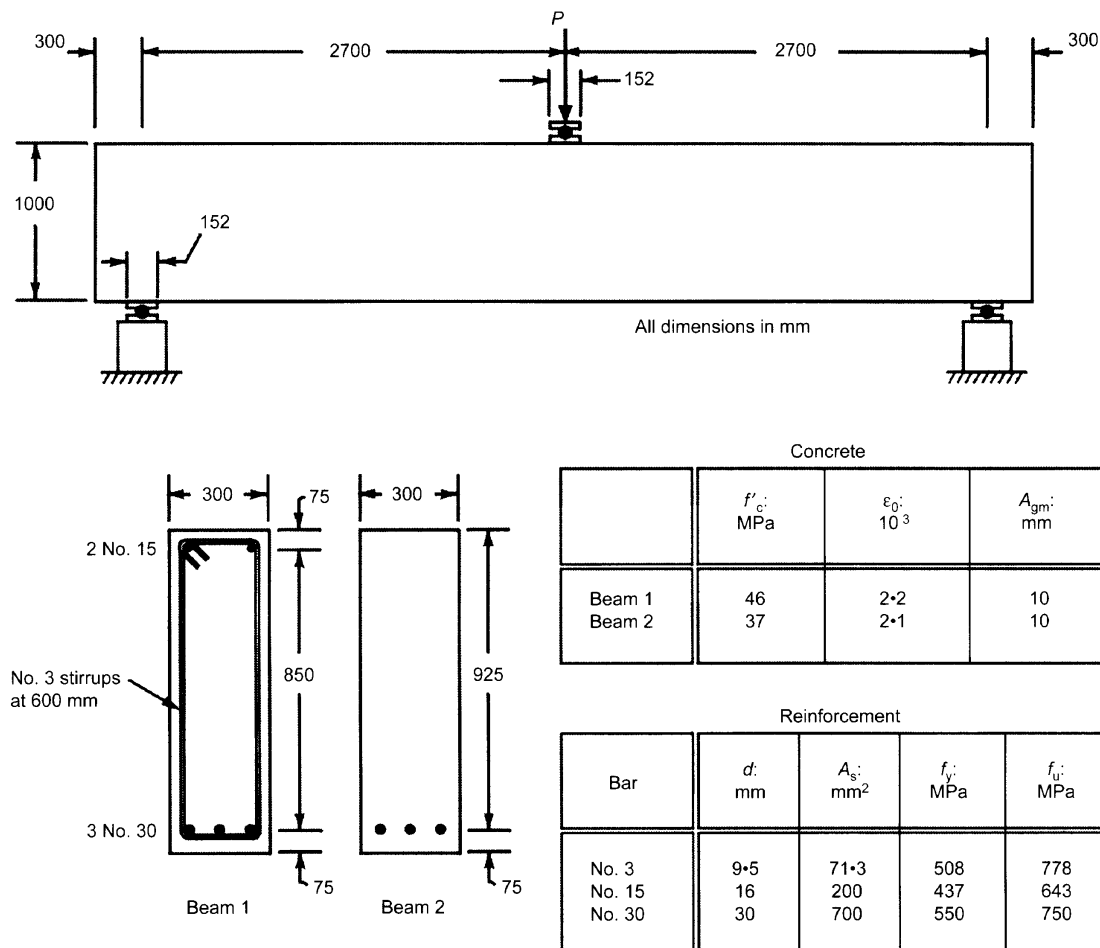

Fig. 7 Details of Podgorniak-Stanik test beams

Table 1 Results of analyses of Podgorniak-Stanik beams

Analyst No.	$M_u$ (kN m)	$V_{u1}$ (kN)	$V_{u2}$ (kN)	$P_u/2$ (kN)	$\delta_u$ (mm)
Results for Beam No. 1					
1	1013	366	431	380	19.9
2	996	488	423	273	10.6
3	1070	366	350	323	15.7
4	1076	488	435	443	69.0
5	1072	488	369	270	14.1
6	1010	488	285	432	21.2
7	1017	488	423	394	25.0
8	1000	488	440	385	16.0
9	1011	488	423	410	30.3
10	978	488	342	430	54.0
Mean	1024	464	392	374	27.6
COV (%)	3.4	11.1	13.4	17.1	69.1
Results for Beam No. 2					
1	998	228	192	249	13.9
2	993	228	211	149	4.5
3	1034	228	183	139	4.5
4	1041	169	174	297	17.6
5	1015	228	180	210	8.1
6	993	228	195	214	5.4
7	1002	228	166	251	15.0
8	982	169	185	199	6.5
9	1004	338	282	345	24.8
10	966	228	209	300	20.0
Mean	1003	227	198	235	12.0
COV (%)	2.3	20.2	16.6	28.2	60.4

experienced in its use. Differences arose primarily from the selection of material behaviour models available within the program library, and from the modelling of details such as reinforcement (smeared or discrete) and support/loading conditions. (Incidentally, the experimentally observed peak load and corresponding deflection for Beam No. 1 were 672 kN and 20.7 mm; for Beam No. 2, 370 kN and 5.9 mm.)

#### Voluminous data

NLFEA investigations invariably produce large quantities of data, typically spawning output files of several megabytes in size or larger for each load stage. Information may be provided on: stresses and strains at each integration point of each element, both with respect to local and principal axes, both for the element and for the concrete component; nodal displacements; sectional forces per unit width at each integration point; reactions; reinforcement stresses and strains; stiffness matrix coefficients, and more. Considering that typical problems can involve tens of thousands of degrees of freedom, the total amount of data quickly escalates to the point where the use of post-processors is virtually essential. Even then, the analyst must have an awareness of what to look for and how to interpret it. Despite the use of sophisticated post-processors and graphics capabilities, there remains the possibility for misinterpretation. Errors in the processing and interpretation of FEA data were partly responsible for the



underestimation of shear forces on the tricell wall, and ultimately contributed to the collapse and loss of the \$700M Sleipner A offshore platform.<sup>2</sup>

*Incomplete knowledge*

One must accept that we still do not understand well, let alone have accurate models for, many aspects of reinforced concrete behaviour. (See 'A challenging set of test results' below.) Applications of NLFEA should be done with a healthy degree of caution and scepticism. Wherever possible, analysis software and models should be validated or calibrated against benchmark tests involving specimens of similar construction and loading details, dependent on mechanisms anticipated to be significant in the analysis problem at hand (as far as this can be done). Wherever possible, results should be supported by analyses based on different models or approaches.

*Research philosophy*

Lastly, it must be said that the research community, and associated technical committees, may have failed the profession in some respects. Many working in the area have directed their

efforts to developing sophisticated models and methods of analysis, in many cases basing their work on esoteric models or rigorous application of classical mechanics approaches not directly suited to reinforced concrete. Consequently, advancements have been made in developing the NLFEA concepts and methodologies, but often with reinforced concrete being merely the application. Unfortunately, reinforced concrete is a complex and stubborn material that sometimes refuses to act according to accepted rules of mechanics. Researchers might do well to re-focus some efforts towards better understanding and modelling of reinforced concrete behaviour, with finite element analyses being merely the tool. Certainly, however, there is room and a need to advance on both fronts.

**A challenging set of test results**

To reinforce the notion that we still do not know enough about the behaviour of reinforced concrete, and to provide a challenge to those who might think otherwise, consider two series of beams tested by Angelakos *et al.*<sup>10</sup>

The first series involved five beams, which were 6000 mm in length, 1000 mm in depth, 300 mm wide, reinforced with approximately 1.0% longitudinal reinforcement, contained no transverse

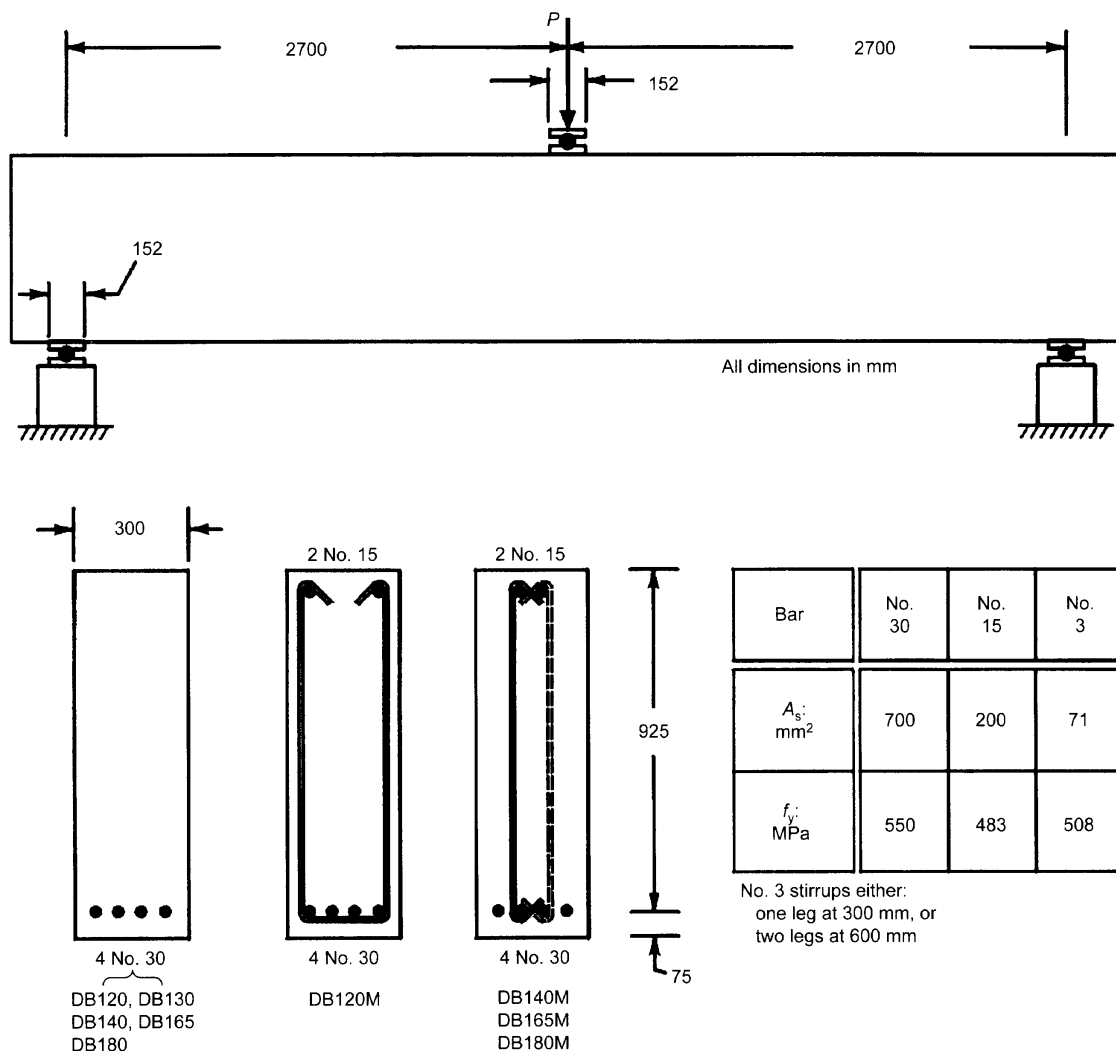

**Fig. 8** Details of Angelakos test beams

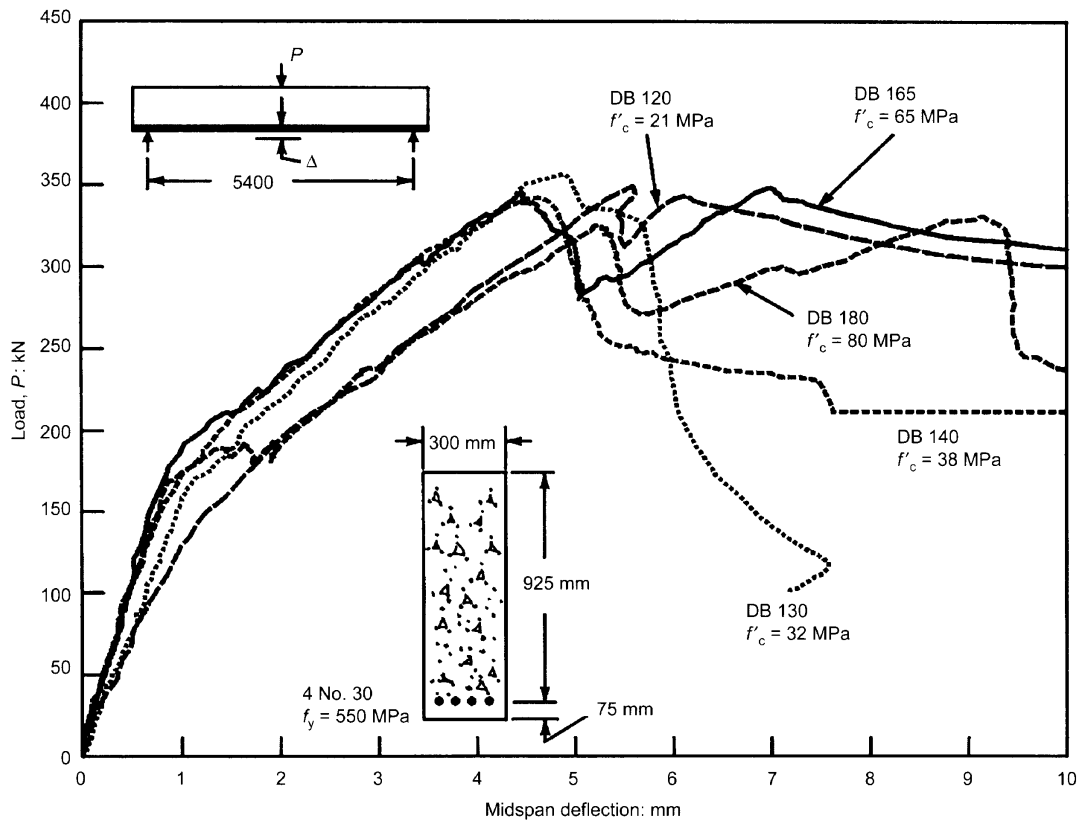

Fig. 9 Observed load–deformation response of Angelakos Series I beams (beams containing no shear reinforcement)

reinforcement, and were subjected to a monotonically increasing load applied at the midspan. (Beams DB120, DB130, DB140, DB165 and DB180; see Figure 8 for beam details.) The only variable was the compressive strength of the concrete, ranging from 20 MPa to 80 MPa. These beams failed in a shear-critical manner upon the formation of the first web shear crack. Current design code formulations would say that the shear strength of these beams is directly proportional to a 'concrete contribution' related to the tensile strength of the concrete, which in turn is normally related back to the compressive strength (typically, the tensile strength is taken as proportional to the square root of the compressive strength). Hence, the 80 MPa beam would be expected to have a shear strength of close to double that of the 20 MPa beam. Finite element analyses could also be expected to produce similar trends in predicted strength, since the concrete tensile strength is the over-riding parameter in most analyses of such cases. Shown in Figure 9 are the load–deformation responses measured experimentally. Note that there is little difference in the strengths and pre-peak deflection responses observed; certainly nothing approaching the doubling of strength anticipated. In fact, the 80 MPa beam exhibits a shear strength lower than the 20 MPa beam. At work are mechanisms related to smoothness of the fracture plane, aggregate interlock mechanisms, and crack slip mechanisms.

A second series of beams from the same test programme involved four beams similar in dimensions and loading to the first. (Beams DB120M, DB140M, DB164M and BD180M; see Figure 8). The principal difference was that these beams contained the near-minimum amount of shear reinforcement (0.22%). Again, the compressive strength of the concrete ranged from 20 MPa to 80 MPa. Shown in Figure 10 are the load–deformation responses recorded.

Note that here, a small amount of shear reinforcement had a substantial influence on the strength and failure mechanisms observed. Although the higher strength concrete beams did exhibit a higher shear strength, there was still a good deal of perplexing behaviour observed. See Angelakos<sup>10</sup> for a more complete description of the test program, and a more thorough discussion of results and significance.

These two series of test results will provide a stringent test of any NLFEA model. Would-be analysts are encouraged to formulate all structural models, and select all constitutive models and analysis parameters in advance of any 'preliminary' computations, and to conduct the analyses in a group and only once (i.e. eschew any calibration or fine-tuning work).

### Future work

In addition to ongoing work in the development of improved constitutive models and analysis procedure, research effort is also required to make NLFEA procedures more amenable to practical application and to remove some of the concerns regarding accuracy and consistency. Specific short-term objectives should include the following.

- (1) Provide design engineers and non-experts with guidance in the application of NLFEA procedures to common and practical problems.
- (2) Establish databanks and benchmark problems, for various structure types and loading conditions, to facilitate the validating or calibrating of material behaviour models and analysis procedures.
- (3) Recognise that diversity in the analysis procedures available

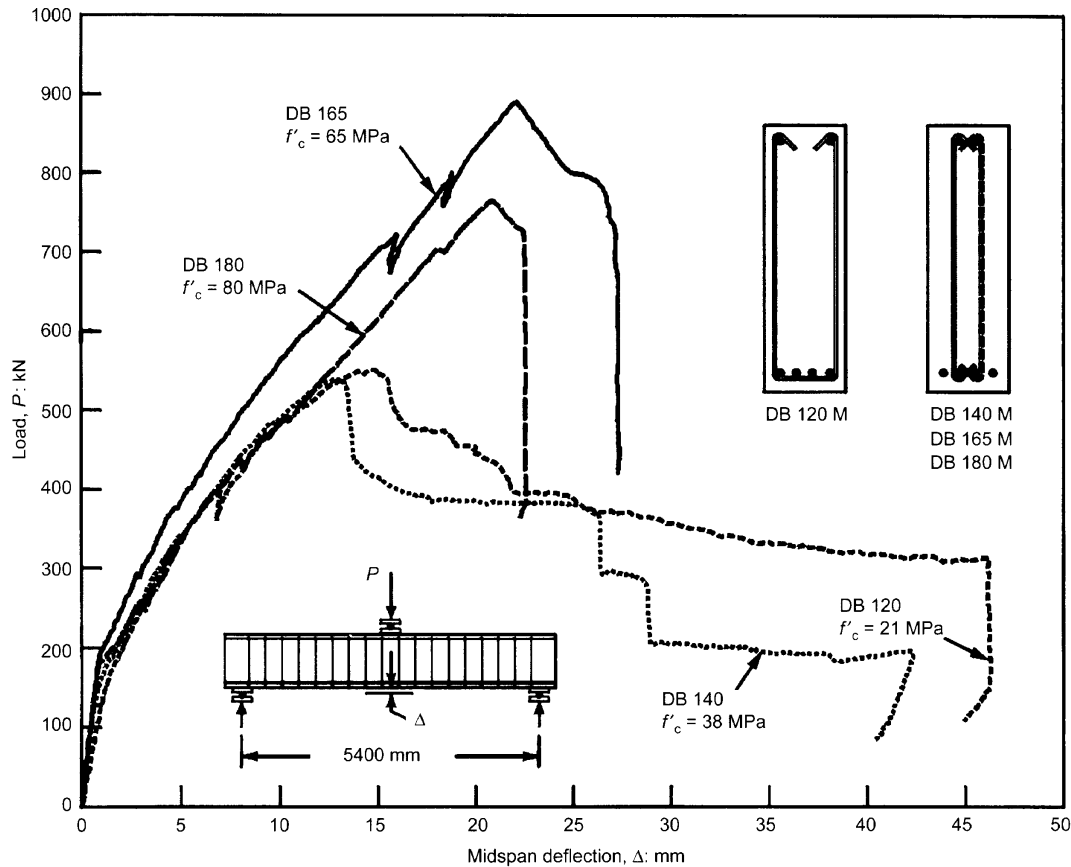

Fig. 10 Observed load–deformation response of Angelakos Series II beams (beams containing shear reinforcement)

is itself valuable, and should be encouraged. At the same time, work towards the harmonisation of constitutive models and analysis approaches must proceed where appropriate. The identification and description of relevant behaviour mechanisms, and suitable models for their representation, should be accentuated.

- (4) Provide guidance on modelling issues relating to assessment, rehabilitation and forensic engineering; areas where NLFEA procedures are finding significant use today.
- (5) Work towards developing accurate, consistent and easy-to-use automated design software, with NLFEA being one of the viable means of performing background calculations.

Task Group 4.4 (Computer-Based Modelling and Design), of *fib* Commission 4 (Modelling of Structural Behaviour and Design) is currently working towards addressing these objectives.

## Conclusions

The state-of-the-art in the non-linear finite element analysis of reinforced concrete structures has advanced significantly in recent years. The speed and accuracy of analyses have progressed to the point where NLFEA software is close to being a vital design office tool, useful in many types of practical applications. In coming years, such analyses may well form the heart of advanced software for automated design, albeit in a form transparent to the user.

However, NLFEA models and procedures for reinforced concrete remain complex, fragmented, and fraught with dangers.

The user of these procedures must be experienced, cautious and somewhat sceptical.

Future work must be directed at developing improved material behaviour models that more accurately represent the behaviour of reinforced concrete under the diverse conditions encountered in practice. Furthermore, efforts are needed in reconciling the incompatibilities of models and approaches, and in reducing the potential for errors in modelling, analysis and interpretation of results. Advances in these areas will determine, in large part, if NLFEA can ascend to a higher level of acceptance and use.

## References

1. Bentz, E. C. Presentation at ACI Annual Convention, Toronto, October 2000.
2. Collins, M. P., Vecchio, F. J., Selby, R. G. and Gupta, P. R. The failure of an offshore platform, *ACI Concrete International*, 1997, **19**, No. 8, 28–35.
3. Collins, M. P., Vecchio, F. J. and Mehlhorn, G. An international competition to predict the response of reinforced concrete panels, *Canadian Journal of Civil Engineering*, 1985, **12**, No. 3, 624–644.
4. Nuclear Power Engineering Corporation (NUPEC) *Comparison Report, Seismic Shear Wall ISP, NUPEC's Seismic Ultimate Dynamic Response Test*, 1996, Report No. NU-SSWISP-D014.
5. American Concrete Institute, Special Publication, in press.
6. Vecchio, F. J. and Collins, M. P. The modified compression field theory for reinforced concrete elements subjected to shear, *Journal of the American Concrete Institute*, 1986, **83**, No. 2, 219–231.
7. Okamura, H. and Maekawa, K. *Non-linear analysis and constitutive models of reinforced concrete*. University of Tokyo, 1991.
8. Vecchio, F. J. Disturbed stress field model for reinforced concrete: Formulation, *ASCE Journal of Structural Engineering*, 2000, **126**, No. 9, 1070–1077.

9. Podgorniak-Stanik, B. The influence of concrete strength, distribution of longitudinal reinforcement, amount of transverse reinforcement and member size on shear strength of reinforced concrete members. MSc Thesis Department of Civil Engineering, University of Toronto, 1998.
10. Angelakos, D., Bentz, E. C. and Collins, M. P. The effect of concrete strength and minimum stirrups on the shear strength of large members, *ACI Structural Journal*, 2001, **98**, No. 3, 290–300.

**Frank J. Vecchio**

Department of Civil Engineering, University of Toronto,  
35 St. George Street, Toronto, Canada M5S 1A4